



Sean Doyle & Sons Ltd.

IRELAND'S ONLY
MANUFACTURER OF NORDWIN
ALUCLAD WINDOWS



IRISH ALUCLAD WINDOWS

Sean Doyle
& Sons Ltd.

IRELAND'S LEADING
ALUCLAD PROVIDERS

HOW DOYLES & ALUCLAD WORK

In Ireland we expect the best raw materials, engineering, and design and of course, service.

SINCE THE 80'S S DOYLE & SONS HAS BROUGHT A HUMAN TOUCH AND THE VERY BEST MATERIALS TO ITS WINDOWS AND DOORS.

While they were building superior products, they were also building a reputation for quality materials, fine craftsmanship, remarkable innovation, and exceptional customer service. All of that effort was directed at a single goal: ensuring that each customer received beautiful and long lasting windows - and an extraordinary client experience.



IRISH ALUCLAD WINDOWS

Sean Doyle
& Sons Ltd.

WHY ALUCLAD IS THE NATURAL ADVANTAGE

MODERN MATERIALS WITH A CLASSIC FEEL

- **Wood creates comfort** – it is a feel-good material. Aluminium on the other hand, is a robust protective shield against the elements. Together, they form an aluminium clad wood product which lasts generations without the need for continuous maintenance. It can be used in its natural form (transparent stain) thanks to the aluminium shell. The aluminium shield firmly encases the wood, protecting it from the elements while still giving room to expand and contract.
- **Durability.** Ever since its early days, S Doyle & Sons has always used the highest-quality materials. Down to the finest detail, we use smooth glazing seals made from synthetic rubber. The high-quality workmanship and strict quality controls ensure you gain long-term enjoyment from your Alu Clad window.
- **Freedom of design.** Tastes are subjective. That's why you can choose from our large range of wood finishes and many different aluminium colors/patterns.
- **Energy efficiency** and solid construction style not only guarantees durability, but also help save energy. Each of our aluminium clad wood products has state-of-the-art "warm-edge" spacers between the glass panes, ensuring better thermal values, greater comfort near the window, and significantly reduced condensation build-up during colder months. Heating costs can be further reduced through highly efficient triple-pane glass with a thickness up to 44 mm.

WHY ALU CLAD WORKS

WHY IT WORKS SO WELL. AND LOOKS SO GOOD
COME AND SEE WHY

Alu Clad windows and doors combine a timber interior with an aluminium exterior enhancing their style and design with the attractive benefit of minimal maintenance. The combination of the Powder Coated Aluminium on the outside and the warmth and beauty of timber to the interior makes Alu Clad windows and doors exceptionally weather resistant and also very thermally efficient.

- Alu Clad windows and doors are sometimes referred as timber clad windows and are possibly the fastest growing window type in **Ireland and the UK**. With the benefits of an Aluminium exterior, Alu Clad windows and doors require little or no external maintenance and maintain their look for many years. All our Alu Clad windows come Polyester Powder Coated and can be fabricated in the colour of your choice with a satin, gloss or matt finish.
- Top grade laminated timber is used to create a robust design. During manufacture the timber has a base coat protection applied prior to cladding ensuring maximum durability in all weather. The Internal timber can be painted to a colour of your choice or stained to show the natural grain of the wood.
- All our Alu Clad windows can be made in many styles of frame, our most popular styles include: Tilt and Turn Windows or Traditional Casement Windows.
- All our Alu Clad windows (and doors) are provided with an option to upgrade from our standard Double glazing to the latest Triple glazing technology. This means with the movement towards low carbon properties your new windows (or doors) will offer the maximum advantages in both insulation and efficiency.
- Our Triple glazed windows are perfect for Passivhaus (Passive House) construction or to upgrade/replace existing windows and are manufactured to the exacting standards required for a fully certified Passivhaus window and door range. We offer a full technical advice, design and installation service if required and can help you with making the decision that will best suit you. Please contact us and we'll be pleased to help.



IRISH ALUCLAD WINDOWS





Sean Doyle
& Sons Ltd.



IRISH ALUCLAD WINDOWS



WINDOWS ARE WHITE – RIGHT?

THE ALU CLAD COLOUR DIFFERENCE

Teknos Total Factory Applied Protection (TFAP) systems allow joinery manufacturers to produce fully engineered exterior joinery, with almost unlimited colour choice, in a single integrated finishing process.

By combining topically applied preservation technology, novel end-grain and joint sealing with protective basecoats and a flexible microporous paint system, the Teknos system allows manufacturers to meet the latest European performance standards whilst reducing process times and working capital.

Independently accredited and environmentally sensitive, the Teknos microporous paint system marks another significant step in improved joinery quality and performance from one of Europe's leaders in industrial wood coatings.





TEKNOS COMMITTED TO QUALITY PROTECTING OUR ENVIRONMENT



Teknos, and its joinery manufacturing partners, share a commitment to quality and to meeting and exceeding best practice.



All Teknos' factories have quality and environmental management systems, certified in accordance with ISO 9001 and ISO 14001 and our Industrial Wood plant in Vamdrup also holds an EMAS certificate.

Teknos joinery coatings, in keeping with their Scandinavian heritage, are water based, with VOC levels significantly below current and proposed legislative levels, and free of all heavy metal additives.



RESPONSIBLE FORESTRY / ENVIRONMENT

LOVE THE ENVIRONMENT – LOVE DOYLES

Sean Doyle & Sons environmental stewardship is nothing new. With origins rooted in wood product manufacturing, our legacy has been to make windows, doors and components in a manner consistent with efficient use of what nature provides.

To us, minimizing waste has always made good ecological and business sense. Our mission is to develop high performance, high-value products that satisfy our customers' needs, while also caring for our communities by seeking ways to reduce our impact on the environment.



IRISH ALUCLAD WINDOWS



DIFFERENT MATERIALS AND
DESIGNS. YOU WILL BE
SPOILED FOR CHOICE.

WHAT'S THE LOOK

DESIGN OPTIONS

S Doyle & Sons windows and doors are made strictly to order allowing you to personalise your product with a full range of Design Options to match your project and budget. We also have a large range of fully factory finished white windows.

GLAZING

We offer a wide range of glass options to suit your budget and project needs.

CHOICE OF WOOD

Our standard windows are manufactured using premium quality, vacuum impregnated, kiln dried, finger jointed and laminated Nordic Red Pine. Hardwoods include Oak, Siberian Larch, Teak or Mahogany.

FACTORY FINISH

All products are offered with a choice of factory finish - in any RAL colour. A robotically applied factory finish guarantees a perfect finish and excellent protection and with a 30% better bond between wood and paint compared to painting on site. Different colours can be applied to the inside and outside. Stains and lacquers may also be applied to interior surfaces.

GLAZING BARS

Glazing bar options include clip-on bars, Georgian bars and applied bars.

HANDLES HINGES & VENTS

Locking or non-locking handles are available in satin anodized, aluminium, brass, brown or white. Vents are available in aluminium, brown or white. Hinges are available in natural, brown, white or any RAL colour.

SUPPLY AND FIT SERVICE

Sean Doyle & Sons offer a Supply and Fit service for all products.



ALUCLAD SYSTEM OFFERS



The Gutmann Look

High Performance window system manufactured from the highest quality Scandinavian pine with an aluminium/timber composite frame and an aluminium/timber sash. The range gives the architect or end user a considerable choice of opening configurations, with options of frame widths. The windows are supplied fully finished in numerous configurations. They are all custom made and can therefore incorporate more unusual designs and shapes.

Architecture thrives on ideas. Sean Doyle & Sons Alu Clad systems offer architects and planners the ability to employ windows and doors in the way the structural concept anticipates, no matter whether the focus is on public or private use. Supporting their creativity and finding extraordinary solutions are a special motivation for us.

Unlike any other system manufacturer, NORDWIN relies on the modularity, versatility and compatibility of their products. NORDWIN windows and doors meet all of the requirements of modern architecture.



Filigree appearance provide custom solutions for both residential and commercial buildings. The versatility of our products not only finds expression in the materials used.

Different profile shapes and the almost unlimited possibilities of surfaces and colour finishes increase this exponentially.





IRISH ALUCLAD WINDOWS

DOYLES WILL WORK WITH
YOU UNTIL YOU HAVE THE
LOOK YOU WANT.



www.seandoylewindows.ie

Sean Doyle & Sons Ltd.



The Quality and high performance of our windows and doors combine the natural beauty, character and warmth of timber with excellent design principles that will enhance the property for years to come.

THE PRODUCTS

ALU CLAD NORDWIN DOUBLE GLAZED

External Aluminium Cladding provides maintenance free protection of the timber.

Aluminium is Polyester Powder Coated to a large range of RAL Classic Colours. Some Colours, including metallic and pearl may incur an extra cost.

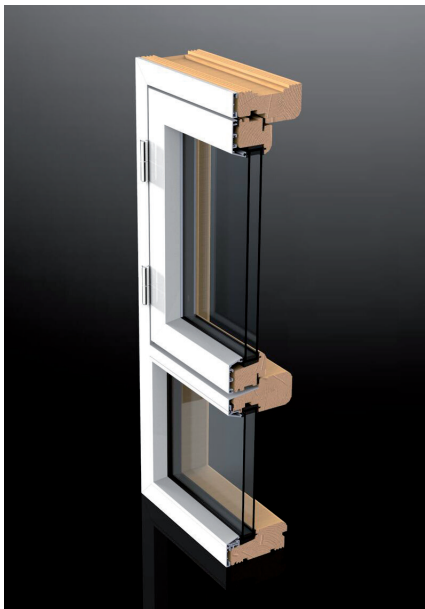

REG No: 52 / 56401
 Manufacturer: S Doyle & Sons Ltd.
 Window system: Nordwin Aluclad Double Glazed
 Issue Date: 09/02/2015
 Valid Until: 09/02/2019

Window Energy Performance (WEP)

Window Energy Performance Rating for this window is: **A**

ENERGY EFFICIENCY (kWh/m² Year) : **9.58**

Energy Index certified by BBA and based on Irish standard window. The actual energy consumption for a specific application will depend on the building, the local climate and the outdoor temperature

CLIMATE ZONE **UK & IRL**

ENERGY PERFORMANCE CRITERIA

Thermal Transmittance	U window	= 1.28 W/m ² .k
Effective Air Leakage	L factor	= 0.01 W/m ² .k
Solar Factor	g window	= 0.50

ADDITIONAL PERFORMANCE CRITERIA

Condensation Resistance	CR	= N/A
-------------------------	----	-------

This label is not a statutory requirement. It is a voluntary label provided as a customer service to allow consumers to make informed decisions on the energy performance of competing products

ALU CLAD NORDWIN TRIPLE GLAZED

1. Energy efficient Triple-glazing to give overall U-Value of up to 0.8W/m²k (Pine).
2. The glazing unit is embedded into the sash by 20mm, improving thermal insulation.
3. Aluminium drip rails preserve the life of the timber and provide effective drainage of water.
4. Laminated sections of either Pine, Meranti or Oak.
5. 4 continuous gaskets for ultimate performance against weather and noise.
6. Secretly fixed internal beading for enhanced security.

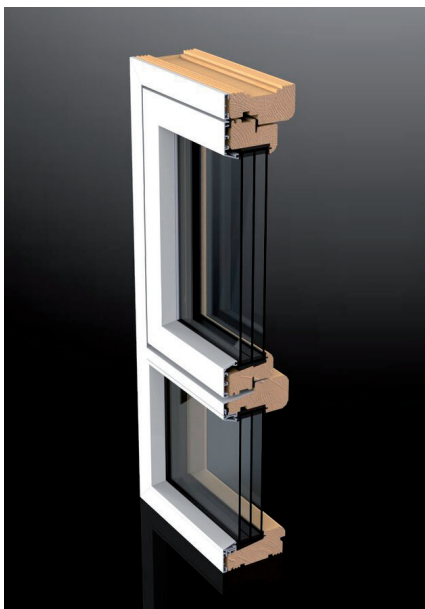

REG No: 52 / 56402
 Manufacturer: S Doyle & Sons Ltd.
 Window system: Nordwin Aluclad Treble Glazed
 Issue Date: 09/02/2015
 Valid Until: 09/02/2019

Window Energy Performance (WEP)

Window Energy Performance Rating for this window is: **A**

ENERGY EFFICIENCY (kWh/m² Year) : **9.58**

Energy Index certified by BBA and based on Irish standard window. The actual energy consumption for a specific application will depend on the building, the local climate and the outdoor temperature

CLIMATE ZONE **UK & IRL**

ENERGY PERFORMANCE CRITERIA

Thermal Transmittance	U window	= 0.08 W/m ² .k
Effective Air Leakage	L factor	= 0.01 W/m ² .k
Solar Factor	g window	= 0.40

ADDITIONAL PERFORMANCE CRITERIA

Condensation Resistance	CR	= N/A
-------------------------	----	-------

This label is not a statutory requirement. It is a voluntary label provided as a customer service to allow consumers to make informed decisions on the energy performance of competing products



www.seandoylewindows.ie

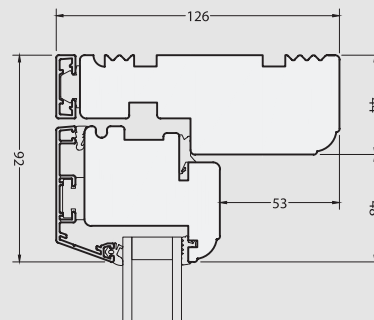
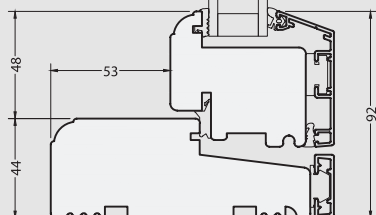
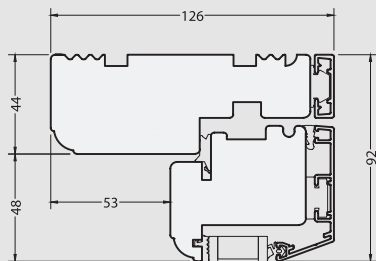

DOUBLE GLAZED

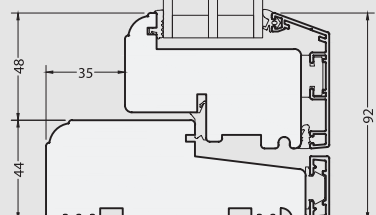
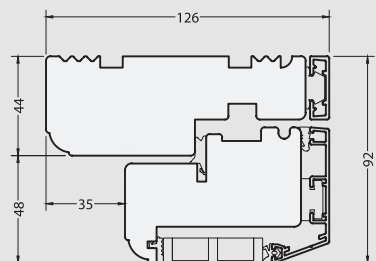
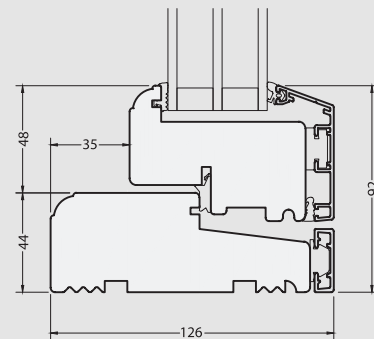
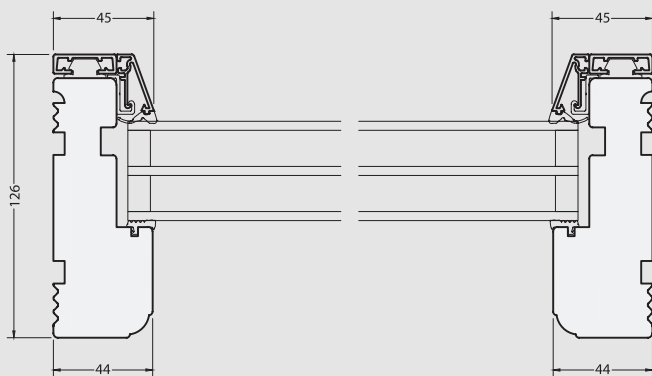
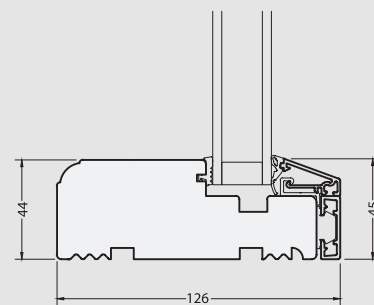
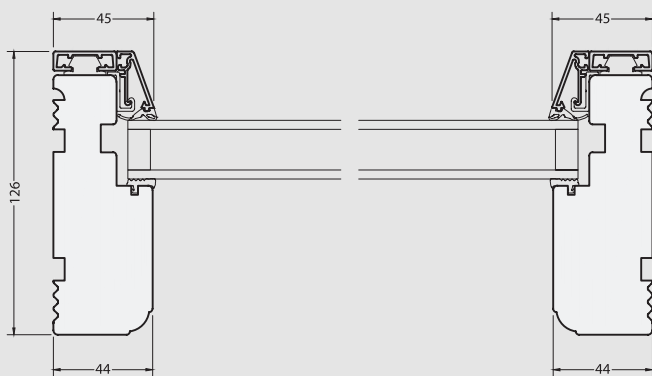

TRIPLE GLAZED

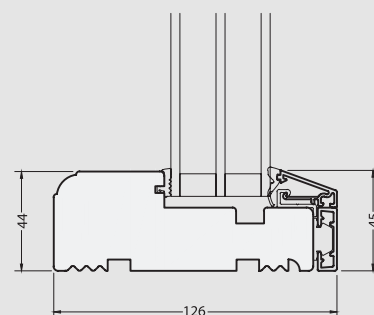



ALU CLAD NORDWIN LIFT & SLIDE

A Lift and Slide patio door is best for locations such as balconies, terraces and other places where there is not enough room for traditional outward or inward opening solutions, or where there is a need for large glazed areas.

Our sliding doors have been fitted with the modern and high-quality Sigenia AUBI HS Portal closing system which was developed in Germany and can carry a maximum load of 200 kilograms. The door with its secure multi-point locking can be closed using the cremone bolts which can also be easily and conveniently locked in a ventilation position.

Nordic's sliding patio doors are equipped with the high quality and modern GU-934-H hinge system which has load bearing capability of 300 kg. The active leaf is located on the inner side of door ensuring functionality during winter and ice or snow does not damage rails. The espagnolette and strong handle enable convenient operation and allow the door to close in a ventilated position.

BBA APPROVAL
INSTITUTION
TESTING
CERTIFICATION

CERT No: SDS-001 - Rev 3 TLL 2015
 Manufacturer: S Doyle & Sons Ltd.
 Window system: Alu Clad Lift & Slide Patio door
 Issue Date: 08/05/2015

Window Energy Performance (WEP)

Window Energy Performance Rating for this is: **A**

ENERGY EFFICIENCY (kWh/m² Year) : **9.58**

Energy Index certified by BBA and based on Irish standard window. The actual energy consumption for a specific application will depend on the building, the local climate and the outdoor temperature.

CLIMATE ZONE **UK & IRL**

ENERGY PERFORMANCE CRITERIA

Thermal Transmittance Solar Factor	U window G door	= 1.4 W/m ² .k = 0.47
---------------------------------------	--------------------	-------------------------------------

ADDITIONAL PERFORMANCE CRITERIA

Condensation Resistance	CR	= N/A
-------------------------	----	-------

This label is not a statutory requirement. It is a voluntary label provided as a customer service to allow consumers to make informed decisions on the energy performance of competing products

ALU CLAD NORDWIN TILT & TURN

The multiple function of the Thermo 80 & Elite 92, tilt and turn windows, makes them a very popular choice on many projects for commercial residential and domestic use.

With enhanced security options to provide compliance with Secured by Design and with many optional accessories for safety and comfort, this system caters for the whole market, and is available at a very competitive price. Thermo 80 & Elite 92 products have a uniform profile height. This allows the installation of window with higher insulation in parts of the building which are exposed to greater heat losses (e.g. the northern facade) different types of windows will be indistinguishable, even within one room, allowing you to economise on heating costs without compromising on aesthetics.

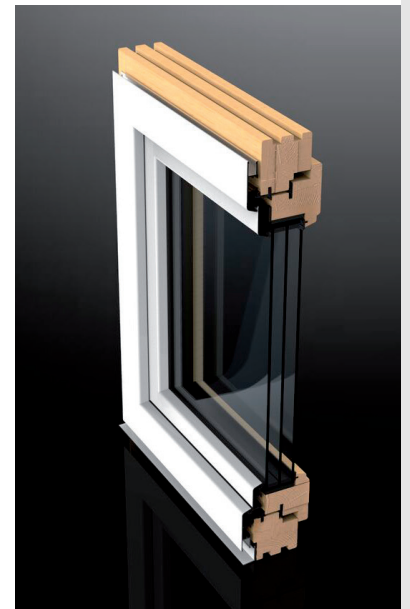
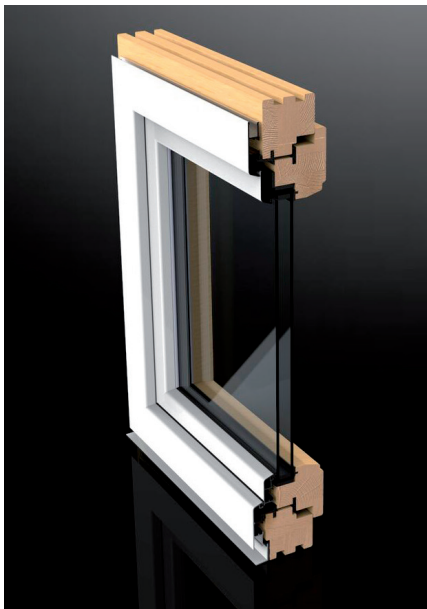



LIFT & SLIDE

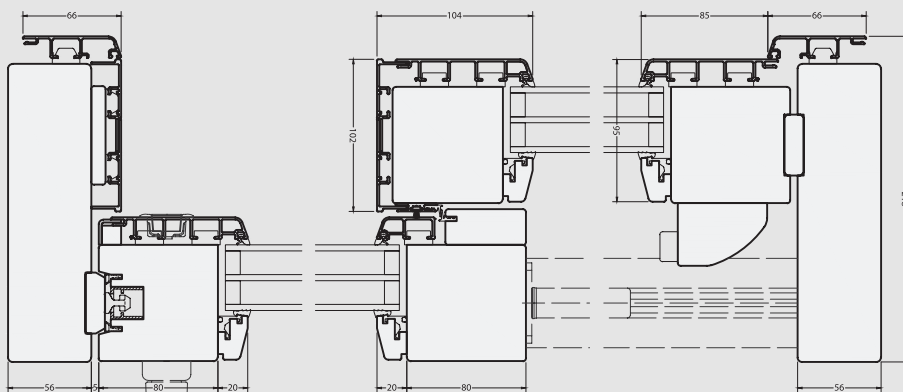
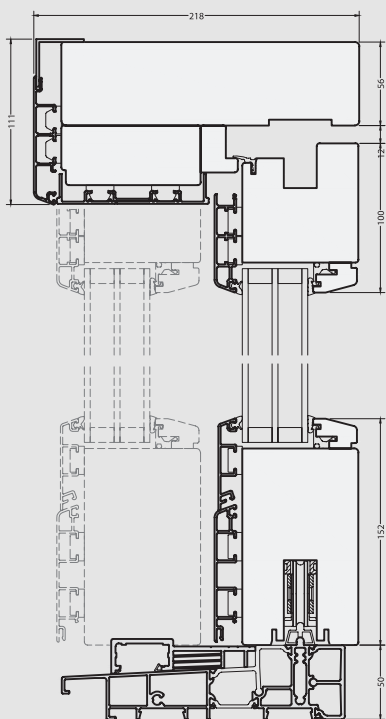

TILT & TURN

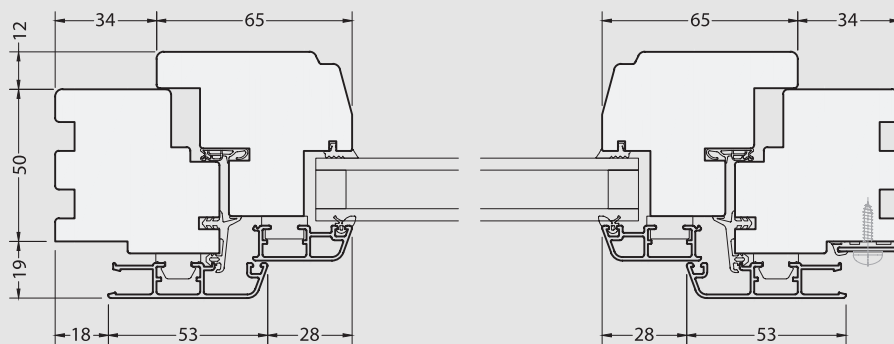
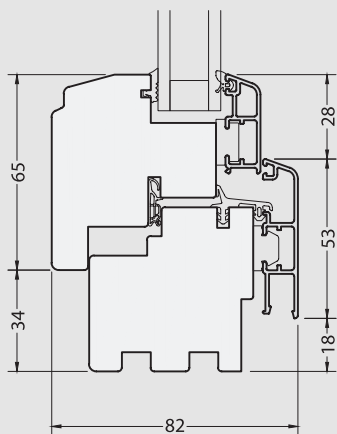



IRISH ALUCLAD WINDOWS

WHEN IT FEELS LIKE
HOME.

www.seandoylewindows.ie

Sean Doyle & Sons Ltd.



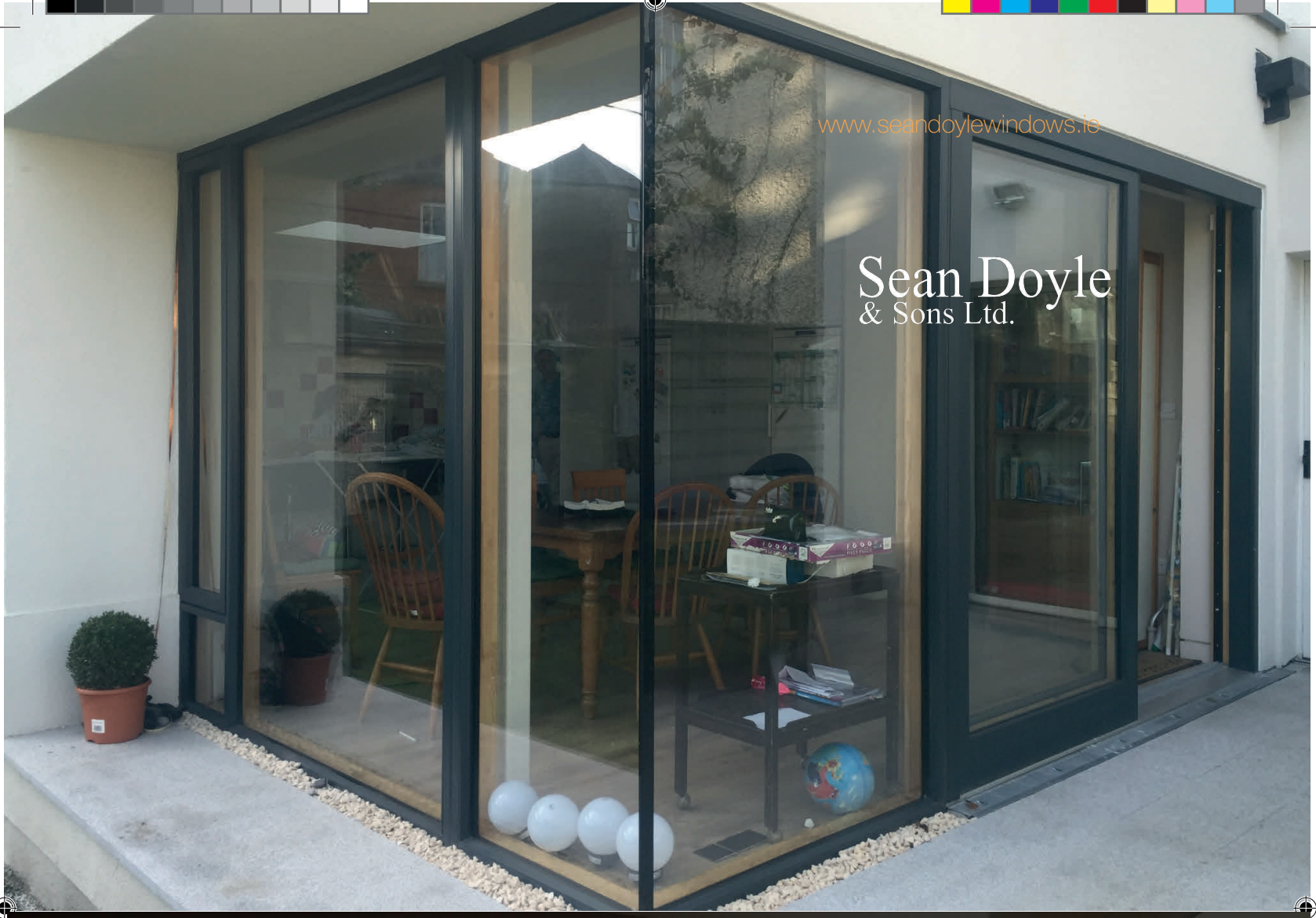



OUR GUARANTEE

S Doyle & Sons have **over 30 years** experience in the design and manufacturing of windows and doors. You get to share that experience when you work with us ensuring that your windows and doors are delivered on time, meet the standard you have been promised and that you enjoy a professional service.

Our Alu Clad System has Aluminium on the outside and multi layered Nordic pine on the inside. The advantage of the aluminium on the outside is that it is impervious to the weather and provides a protective barrier against the elements, while the wood on the inside gives your room a feeling of warmth and natural beauty.

The Quality and High Performance of our windows and doors combine the natural beauty, character and warmth of timber with excellent design principles that will enhance the property for years to come.



IRISH ALUCLAD WINDOWS



ICON: AESTHETIC FUNCTIONALITY

Icon Patio is a highly insulated slide and lift-slide system, which meets the highest requirements with regard to insulation, stability and safety.

Icon Patio is available with various opening possibilities. The low threshold option offers a solution to improve the buildings accessibility. A special corner solution makes it possible to open up spaces without any fixed corner element, creating a perfect and clear continuity between the indoor and outdoor spaces. This makes Icon Patio ideal for rooms with a view.

This robust system allows the construction of large and stable sliding windows and doors with a vent weight up to 300 kg. It also offers an aesthetical slimline middle section. Additionally, Icon Patio can comply with burglar resistance class 2, offering a safe and secure solution.



INTERIOR & EXTERIOR BECOME ONE

A sliding door opens up a multitude of possibilities. Through a sliding door, the garden is incorporated into the interior of the house, fading the interior, exterior border. This creates an extra feeling of space and generates more natural light within the home.

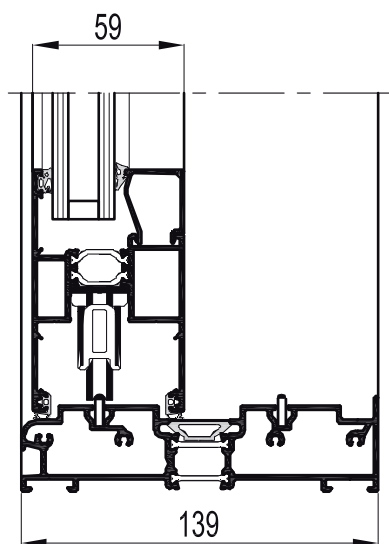

ICON PATIO LIFT & SLIDE

All types of Icon Patio sliding doors use durable wheels and stainless steel rails, for optimal opening comfort. In case of a Lift & Slide system, the sliding door will be lifted up before sliding across this rail.

In the closed position, the Lift & Slide door is put down and anchored, which is an extra plus for insulation and theft prevention. Both systems are wind, waterproof and hermetically sealed.







Sean Doyle
& Sons Ltd.



27



ROSCOMMON

Sean Doyle's & Sons Ltd.
Circular Road,
Roscommon,
Co Roscommon
T: 090-6626753
F: 090-6625438

E: info@seandoylewindows.ie

DUBLIN

Sean Doyle & Sons Ltd.
Whitestown Business Park,
Whitestown Ind Est,
Tallaght, Dublin 24.
T: 01-4626671
E: info@seandoylewindows.ie

FIND US ON FACEBOOK!



www.facebook.com/SeanDoyleWindows

WWW.SEANDOYLEWINDOWS.IE

